

CoroMill® 331

Universele schijffrees

Toepassing

- Groeffrezen
- Afsteken
- Tweezijdig snijdende schijffrezen (dubbel)
- Frezen van opstaande kanten
- Vlakfrezen
- Bewerking met set frezen
- Circulair hellend frezen

ISO toepassingsgebied:



Voordelen en kenmerken

- Uitgebreid programma van opspanopties
- Cassettevergrendeling d.m.v. wig
- Nauwkeurigheid, betrouwbaarheid en stabiliteit dankzij vertanding
- Soms zit de exacte maat die u nodig heeft niet tussen de standaardmaten. Wanneer dat het geval is, neem dan contact op met onze Tailor Made service.
- Gemakkelijke instelling voor de gewenste breedte
- Veerbelaste cassette
- Met veiligheidspen geregeld instelbereik
- Inwendige koelvloeistof



www.sandvik.coromant.com/coromill331

Koppelingen

- Borst met spiebaan
- Doorn
- Cilindrische schacht
- Instelbare zittingen voor hoge precisie
- Vaste zittingen voor hoge tanddichtheid

Wisselplaten

- Licht snijdende wisselplaat met H-tolerantie voor de meeste materialen
- Opties met ronde wisselplaten en een groot assortiment van hoekradii
- Wisselplaten met acht snijkanten voor vlakfreesbewerkingen verkrijgbaar.
- Wisselplaatgeometrieën en hardmetaalsoorten voor alle materialen



Nauwkeurigheid, betrouwbaarheid en stabiliteit dankzij vertanding.

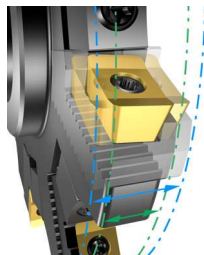

Groot instelbereik

Instelbare zittingen voor flexibiliteit.



I116



I130



N6

Tweezijdig

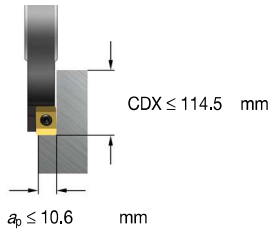

Tailor Made
Dubbele tweezijdig snijdende schijffrees

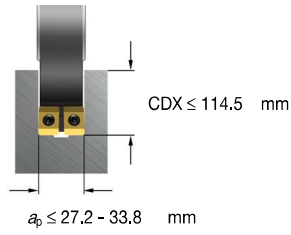

Tailor Made
"Vol" groeffrezen met radius

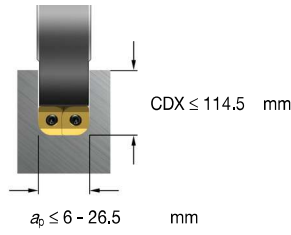

Volledige radius

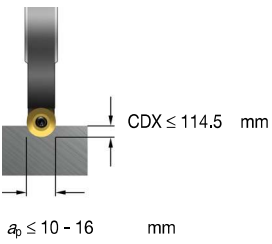

Volle groef vaste zitting

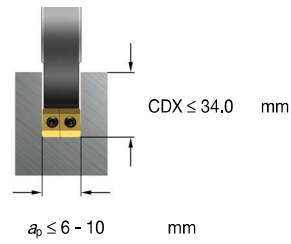

Volle groef cassette

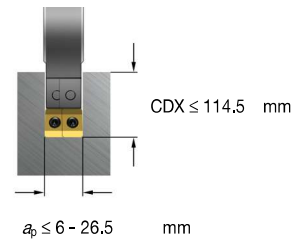

Tailor Made

Cassettefrezen worden vooringesteld geleverd op minimale groefbreedte. Tailor Made voor frezen ingesteld op andere breedtes.

Frezen voor verschillende groefbreedtes en beschikbare wisselplaten

Freesbody's		Wisselplaat afmeting	Neutrale wisselplaten		Linkse en rechtse wisselplaten				
Groefbreedtebereik mm	Freesversies (eind van code)		Radius (RE) 0,5 mm	Radius (RE) 0,8 mm	Radius (RE) 1,52 mm	Radius (RE) 2,29 mm	Radius (RE) 3,05 mm	Radius (RE) 4,83 mm	Radius (RE) 6,35 mm
6-8	CM	04							
8-10	DM	05							
10-12	EM	08							
12-15	FM	08							
15-17.5	KM	11							
17.5-20.5	LM	11							
20.5-23.5	QM	14							
23.5-26.5	RM	14							

Tailor Made

Overige wisselplaatradii verkrijgbaar als Tailor Made.

Freesbody's, cassettes en wisselplaten om te combineren voor alle toepassingen

Tweezijdig snijdende schijffrees

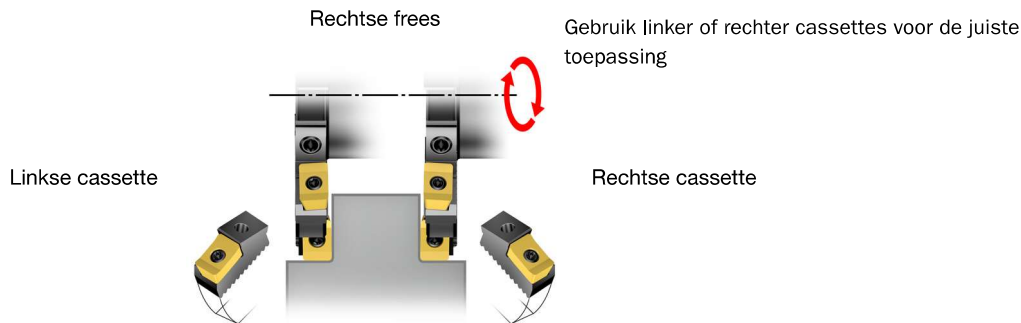

Driezijdig snijdende schijffrees



Gereduceerde snijkantlengte voor Tailor Made wisselplaten

Bij het frezen van sleuven moet de kleinste breedte van de frees worden gebruikt. De overlapping is de meest kritieke factor om te optimaliseren.

Gereduceerde snijkantlengte reduceert overlapping, die op haar beurt slijtage in de overlapzone vermindert, een betere spaanbeheersing oplevert en een verminderd stroomverbruik van zo'n 10%.

Tailor Made wisselplaatopties met gereduceerde snijkantlengte en op aanvraag verkrijgbaar.

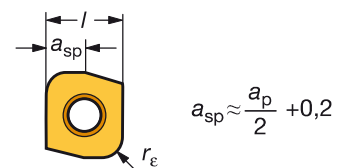
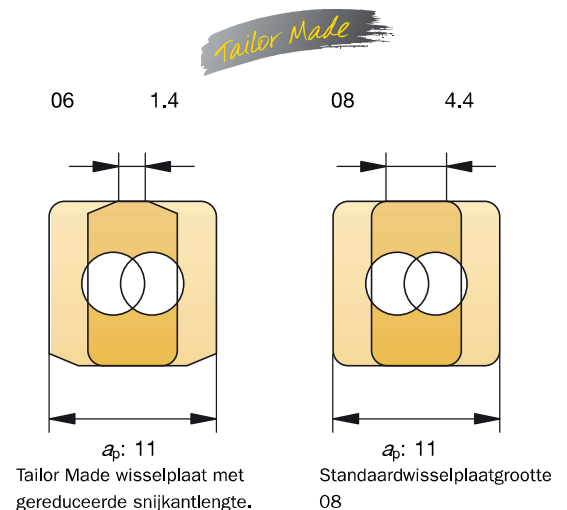

Betere spaanverwijdering

Volsleuffrezen met ronde wisselplaatfrees

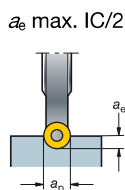

Max. axiale diepte van snede $a_p = IC$
Max. radiale diepte van snede $a_e = IC/2$

a_e meer dan $IC/2$

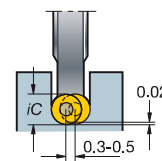

Voor sleuven dieper dan $IC/2$, wordt een 0,3 - 0,5 mm aanpassing van elke cassette aanbevolen. Dit maakt de sleuf 0,5 mm breder en vermindert de contactlengte voor elke wisselplaat tot 90° , waardoor een gunstigere spaanvorming en -afvoer ontstaat, en trillingen en energieverbruik verminderen.

Opmerking: De contactlengte van de snijkant is 180°

CoroMill 331 instelbare schijffrees voor volprofiel- en vlakfrezes

Doornbevestiging - inwendige koelvloeistoftoevoer

STDNO ISO 6462
KAPR 90°

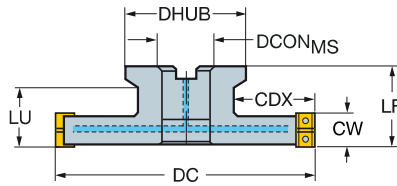

										Afmetingen, mm												
CW	CWX	DC	CDX	CZC _{MS}	CNSC	Bestelnummer				DCON _{MS}	ISO	LF	LU	DHUB	BAR	NM	KG	RPMX	CICT	MIID		
6.00	8.0	80	20.0	04	27	1	3	R331.32C-080Q27CM				27.0	A	50.00	26	51.0	80	0.8	0.51	19300	6	N331.1A-04
		100	22.0	04	27	1	4	R331.32C-100Q27CM				27.0	A	50.00		51.0	80	0.8	0.75	17100	8	N331.1A-04
		125	29.5	04	32	1	5	R331.32C-125Q32CM				32.0	B	50.00		61.0	80	0.8	0.92	15100	10	N331.1A-04
8.00	10.0	80	20.0	05	27	1	3	R331.32C-080Q27DM				27.0	A	50.00		51.0	80	1.2	0.54	15000	6	N331.1A-05
		100	22.0	05	27	1	4	R331.32C-100Q27DM				27.0	A	50.00		51.0	80	1.2	1.01	13200	8	N331.1A-05
		125	29.5	05	32	1	5	R331.32C-125Q32DM				32.0	B	50.00		61.0	80	1.2	1.09	11700	10	N331.1A-05
10.00	12.0	80	20.0	08	27	1	3	R331.32C-080Q27EM				27.0	A	50.00	26	51.0	80	1.2	0.70	18100	6	N331.1A-08
		100	22.0	08	27	1	4	R331.32C-100Q27EM				27.0	A	50.00		51.0	80	1.2	1.10	15900	8	N331.1A-08
		125	29.5	08	32	1	5	R331.32C-125Q32EM				32.0	B	50.00		61.0	80	1.2	1.30	14100	10	N331.1A-08
12.00	15.0	80	20.0	08	27	1	3	R331.32C-080Q27FM				27.0	A	50.00	26	51.0	80	1.2	0.62	18100	6	N331.1A-08
		100	22.0	08	27	1	4	R331.32C-100Q27FM				27.0	A	50.00		51.0	80	1.2	0.92	15900	8	N331.1A-08
		125	29.5	08	32	1	5	R331.32C-125Q32FM				32.0	B	50.00		61.0	80	1.2	1.21	14100	10	N331.1A-08
15.00	17.5	100	25.5	11	27	1	3	R331.32C-100Q27KM				27.0	A	50.00	32.5	51.0	80	3.0	0.98	14000	6	N331.1A-11
		125	29.5	11	32	1	4	R331.32C-125Q32KM				32.0	B	50.00		61.0	80	3.0	1.23	12400	8	N331.1A-11
		160	41.0	11	40	1	5	R331.32C-160Q40KM				40.0	B	50.00		73.0	80	3.0	2.17	10800	10	N331.1A-11
17.50	20.5	125	29.5	11	32	1	4	R331.32C-125Q32LM				32.0	B	50.00		61.0	80	3.0	1.42	12400	8	N331.1A-11
		160	41.0	11	40	1	5	R331.32C-160Q40LM				40.0	B	50.00		73.0	80	3.0	2.35	10800	10	N331.1A-11
20.50	23.5	160	41.0	14	40	1	5	R331.32C-160Q40QM				40.0	B	50.00		73.0	80	3.0	2.63	9000	10	N331.1A-14
23.50	26.5	160	41.0	14	40	1	5	R331.32C-160Q40RM				40.0	B	50.00		73.0	80	3.0	3.00	9000	10	N331.1A-14

Reserve onderdelen				
CW	DC	Wisselplaat-schroef	Wigset	Schroef
6.00	80.00-100.00	5513 020-19	5431 105-07	5516 014-06
6.00	125.00	5513 020-19	5431 105-07	5516 014-06
6.00	160.00	5513 020-19	5431 105-07	5516 014-06
7.90	160.00	5513 020-34	5431 105-06	5516 014-05
8.00	80.00-100.00	5513 020-34	5431 105-06	5516 014-05
8.00	125.00	5513 020-34	5431 105-06	5516 014-05
10.00	80.00-100.00	5513 020-24	5431 105-01	269-832
10.00	125.00	5513 020-24	5431 105-01	269-832
10.00	160.00	5513 020-24	5431 105-01	269-832
12.00	80.00-100.00	5513 020-24	5431 105-02	269-832
12.00	125.00	5513 020-24	5431 105-02	269-832
12.00	160.00	5513 020-24	5431 105-02	269-832
15.00	100.00	5513 020-29	5431 105-04	339-831
15.00	125.00	5513 020-29	5431 105-04	339-831
15.00	160.00	5513 020-29	5431 105-04	339-831
17.50	125.00	5513 020-29	5431 105-04	5516 010-02
17.50	160.00	5513 020-29	5431 105-04	5516 010-02
20.50	160.00	5513 020-29	5431 105-05	5516 010-02
23.50	160.00	5513 020-29	5431 105-05	5516 010-02

Ga voor de complete lijst van reserveonderdelen naar www.sandvik.coromant.com

Onderdelen	
CZC _{MS}	Koelmiddelschroef
27	5512 098-05
32	5512 098-04
40	5512 098-03



I130



L2



M1



N23







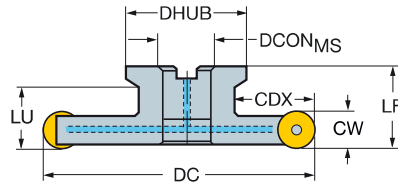

N6

CoroMill 331 instelbare schijffrees voor volprofiel- en vlakfreesen

Doornbevestiging - inwendige koelstoftoevoer

STDNO ISO 6462



							Afmetingen, mm												
CW	DC	CDX		CZC _{MS}	CNSC		Bestelnummer	DCON _{MS}	ISO	LF	LU	DHUB				RPMX	RE	CICT	MIID
10,00	82	21,6	10	27	1	6	R331.32C-082Q27EMQ	27,0	A	50,00	26	51,0	80	1,2	0,59	19500	5,0	6	RCKT 10 T3 M0
	102	23,0	10	27	1	8	R331.32C-102Q27EMQ	27,0	A	50,00		51,0	80	3,0	0,95	15900	5,0	8	RCKT 10 T3 M0
	127	30,5	10	32	1	10	R331.32C-127Q32EMQ	32,0	B	50,00		61,0	80	3,0	1,20	14100	5,0	10	RCKT 10 T3 M0
	162	42,0	10	40	1	12	R331.32C-162Q40EMQ	40,0	B	50,00		73,0	80	3,0	1,85	12400	5,0	12	RCKT 10 T3 M0
12,00	82	21,0	12	27	1	6	R331.32C-082Q27FMQ	27,0	A	50,00	26	51,0	80	3,0	0,66	18100	6,0	6	RCKT 12 04 M0
	102	23,0	12	27	1	8	R331.32C-102Q27FMQ	27,0	A	50,00		51,0	80	3,0	1,00	15900	6,0	8	RCKT 12 04 M0
	127	30,5	12	32	1	10	R331.32C-127Q32FMQ	32,0	B	50,00		61,0	80	3,0	1,29	14100	6,0	10	RCKT 12 04 M0
	162	42,0	12	40	1	12	R331.32C-162Q40FMQ	40,0	B	50,00		73,0	80	3,0	2,03	12400	6,0	12	RCKT 12 04 M0
16,00	102	26,5	16	27	1	6	R331.32C-102Q27KMQ	27,0	A	50,00	32,5	51,0	80	5,0	0,90	14000	8,0	6	RCKT 16 06 M0
	127	30,5	16	32	1	8	R331.32C-127Q32KMQ	32,0	B	50,00		61,0	80	5,0	1,38	12400	8,0	8	RCKT 16 06 M0
	162	42,0	16	40	1	10	R331.32C-162Q40KMQ	40,0	B	50,00		73,0	80	5,0	2,22	10800	8,0	10	RCKT 16 06 M0

Reserve onderdelen					
CW	DC	Cassette neutraal	Wisselplaat-schroef	Wigset	Schroef
10,0	82,00	5521 250-02	5513 020-09	5431 105-01	269-832
10,0	102,00	5521 250-02	5513 020-09	5431 105-01	5516 010-02
10,0	127,00-162,00	5521 250-02	5513 020-09	5431 105-01	339-831
12,0	82,00	5521 250-03	5513 020-09	5431 105-02	269-832
12,0	102,00	5521 250-03	5513 020-09	5431 105-02	5516 010-02
12,0	127,00-162,00	5521 250-03	5513 020-09	5431 105-02	339-831
16,0	102,00-162,00	5521 250-05	5513 020-07	5431 105-04	339-831

Ga voor de complete lijst van reserveonderdelen naar www.sandvik.coromant.com

Onderdelen	
CZC _{MS}	Koelmiddelschroef
27	5512 098-05
32	5512 098-04
40	5512 098-03



I130



L2



M1



N23



N6

CoroMill 331 instelbare schijffrees voor volprofiel- en vlakfrezes

Doorn

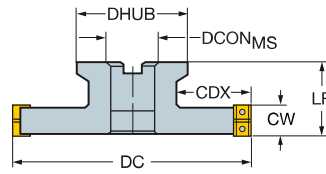
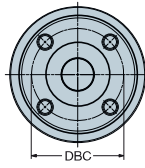
STDNO
KAPRISO6462
90°

N331.1A

								Afmetingen, mm												
CW	CWX	DC	CDX		CZC _{MS}		Bestelnummer	DCON _{MS}	ISO	DBC	LF	DHUB			RPMX	CICT	MIID			
6,00	8,0	200	51,0	04	40S	8	R331.32-200Q40CM06.00	40,0	C	66,7	63,00	96,0	0,8	6,70	11700	16	N331.1A-04			
8,00	10,0	200	51,0	05	40S	8	R331.32-200Q40DM08.00	40,0	C	66,7	63,10	96,0	1,2	8,61	9100	16	N331.1A-05			
10,00	12,0	200	51,0	08	40S	8	R331.32-200Q40EM10.00	40,0	C	66,7	63,00	96,0	1,2	8,88	11000	16	N331.1A-08			
12,00	15,0	200	51,0	08	40S	8	R331.32-200Q40FM12.00	40,0	C	66,7	63,00	96,0	1,2	7,64	11000	16	N331.1A-08			
15,00	17,5	200	51,0	11	40S	6	R331.32-200Q40KM15.00	40,0	C	66,7	63,00	96,0	3,0	9,46	9600	12	N331.1A-11			
		250	56,0	11	60	8	R331.32-250Q60KM15.00	60,0	C	101,6	63,00	136,0	3,0	12,73	8500	16	N331.1A-11			
		315	88,5	11	60	10	R331.32-315Q60KM15.00	60,0	C	101,6	63,00	136,0	3,0	18,32	7600	20	N331.1A-11			
17,50	20,5	200	51,0	11	40S	6	R331.32-200Q40LM17.50	40,0	C	66,7	63,00	96,0	3,0	8,44	9600	12	N331.1A-11			
		250	56,0	11	60	8	R331.32-250Q60LM17.50	60,0	C	101,6	63,00	136,0	3,0	12,76	8500	16	N331.1A-11			
		315	88,5	11	60	10	R331.32-315Q60LM17.50	60,0	C	101,6	63,00	136,0	3,0	20,00	7600	20	N331.1A-11			
20,50	23,5	200	51,0	14	40S	6	R331.32-200Q40QM20.50	40,0	C	66,7	63,00	96,0	3,0	10,30	8000	12	N331.1A-14			
		250	56,0	14	60	8	R331.32-250Q60QM20.50	60,0	C	101,6	63,00	136,0	3,0	13,30	7100	16	N331.1A-14			
		315	88,5	14	60	10	R331.32-315Q60QM20.50	60,0	C	101,6	63,00	136,0	3,0	19,20	6300	20	N331.1A-14			
23,50	26,5	200	51,0	14	40S	6	R331.32-200Q40RM23.50	40,0	C	66,7	63,00	96,0	3,0	10,80	8000	12	N331.1A-14			
		250	56,0	14	60	8	R331.32-250Q60RM23.50	60,0	C	101,6	63,00	136,0	3,0	14,00	7100	16	N331.1A-14			
		315	88,5	14	60	10	R331.32-315Q60RM23.50	60,0	C	101,6	63,00	136,0	3,0	20,44	6300	20	N331.1A-14			

		Reserve onderdelen		
CW	DC	Wisselplaat-schroef	Wigset	Schroef
6,00	200,00	5513 020-19	5431 105-07	5516 014-06
8,00	200,00	5513 020-34	5431 105-06	5516 014-04
10,00	200,00	5513 020-24	5431 105-01	339-831
12,00	200,00	5513 020-24	5431 105-02	339-831
15,00-17,50	200,00-315,00	5513 020-29	5431 105-04	339-831
20,50-23,50	200,00-315,00	5513 020-29	5431 105-05	339-831

Ga voor de complete lijst van reserveonderdelen naar www.sandvik.coromant.com

I130



L2



M1



N23



N6

CoroMill 331 instelbare schijffrees voor volprofiel- en vlakfreesen





Doorn

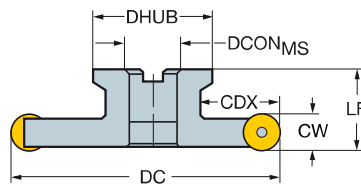
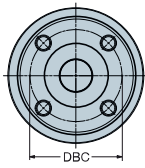

STDNO

ISO6462

RCKT
RCHT

		Afmetingen, mm															
CW	DC	CDX		CZC _{MS}		Bestelnummer	DCON _{MS}	ISO	DBC	LF	DHUB			RPMX	RE	CICT	MIID
10,00	202	52,0	10	40S	16	R331.32-202Q40EMQ	40,0	C	66,7	63,00	96,0	3,0	8,79	11000	5,0	16	RCKT 10 T3 M0
12,00	202	52,0	12	40S	16	R331.32-202Q40FMQ	40,0	C	66,7	63,00	96,0	3,0	9,07	11000	6,0	16	RCKT 12 04 M0
16,00	202	52,0	16	40S	12	R331.32-202Q40KMQ	40,0	C	66,7	63,50	96,0	5,0	10,00	9600	8,0	12	RCKT 16 06 M0

		Reserve onderdelen		
CW	DC	Wisselplaat-schroef	Wigset	Schroef
10,00	202,00	5513 020-09	5431 105-01	339-831
12,00	202,00	5513 020-09	5431 105-02	339-831
16,00	202,00	5513 020-07	5431 105-04	339-831

Ga voor de complete lijst van reserveonderdelen naar www.sandvik.coromant.com

I103



L2



M1



N23



N6

CoroMill 331 instelbare schijffrees voor volprofiel- en vlakfrezes

Baar met spiebaan - interne koelmiddeltoevoer

KAPR 90°

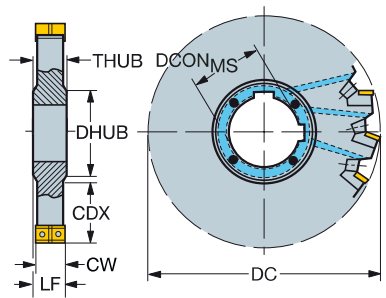

										Afmetingen, mm									
CW	CWX	DC	CDX		CZC _{MS}	CNSC		Bestelnummer	DCON _{MS}	LF	DRVCT	DHUB	THUB				RPMX	CICT	MID
6.00	8.0	80	19.5	04	27	1	3	N331.32C-080S27CM	27.0	10.00	1	39.0	14.0	80	0.8	0.37	19300	6	N331.1A-04
		100	25.5	04	32	1	4	N331.32C-100S32CM	32.0	10.00	1	47.0	14.0	80	0.8	0.49	17100	8	N331.1A-04
		125	34.0	04	40	1	5	N331.32C-125S40CM	40.0	10.00	2	55.0	14.0	80	0.8	0.63	15100	10	N331.1A-04
		160	51.5	04	40	1	6	N331.32C-160S40CM	40.0	10.00	2	55.0	14.0	80	0.8	1.02	13200	12	N331.1A-04
8.00	10.0	80	19.5	05	27	1	3	N331.32C-080S27DM	27.0	12.00	1	39.0	16.0	80	1.2	0.46	15000	6	N331.1A-05
		100	25.5	05	32	1	4	N331.32C-100S32DM	32.0	12.00	1	47.0	16.0	80	1.2	0.59	13200	8	N331.1A-05
		125	34.0	05	40	1	5	N331.32C-125S40DM	40.0	12.00	2	55.0	16.0	80	1.2	0.75	11700	10	N331.1A-05
		160	51.5	05	40	1	6	N331.32C-160S40DM	40.0	12.00	2	55.0	16.0	80	1.2	1.24	10200	12	N331.1A-05
10.00	12.0	80	19.5	08	27	1	3	N331.32C-080S27EM	27.0	13.00	1	39.0	16.0	80	1.2	0.42	18100	6	N331.1A-08
		100	25.5	08	32	1	4	N331.32C-100S32EM	32.0	13.00	1	47.0	16.0	80	1.2	0.62	15900	8	N331.1A-08
		125	34.0	08	40	1	5	N331.32C-125S40EM	40.0	13.00	2	55.0	16.0	80	1.2	0.93	14100	10	N331.1A-08
		160	51.5	08	40	1	6	N331.32C-160S40EM	40.0	13.00	2	55.0	16.0	80	1.2	1.46	12400	12	N331.1A-08
12.00	15.0	80	19.5	08	27	1	3	N331.32C-080S27FM	27.0	14.00	1	39.0	16.0	80	1.2	0.52	18100	6	N331.1A-08
		100	25.5	08	32	1	4	N331.32C-100S32FM	32.0	14.00	1	47.0	16.0	80	1.2	0.69	15900	8	N331.1A-08
		125	34.0	08	40	1	5	N331.32C-125S40FM	40.0	14.00	2	55.0	16.0	80	1.2	1.04	14100	10	N331.1A-08
		160	51.5	08	40	1	6	N331.32C-160S40FM	40.0	14.00	2	55.0	16.0	80	1.2	1.68	12400	12	N331.1A-08
15.00	17.5	100	25.5	11	32	1	3	N331.32C-100S32KM	32.0	16.75	1	47.0	18.5	80	3.0	0.82	14000	6	N331.1A-11
		125	34.0	11	40	1	4	N331.32C-125S40KM	40.0	16.75	1	55.0	18.5	80	3.0	1.23	12400	8	N331.1A-11
		160	51.5	11	40	1	5	N331.32C-160S40KM	40.0	16.75	2	55.0	18.5	80	3.0	2.01	10800	10	N331.1A-11
		17.5	20.5	125	34.0	11	40	1	4	N331.32C-125S40LM	40.0	19.50	1	55.0	21.5	80	3.0	1.41	12400
20.50	23.5	160	51.5	11	40	1	5	N331.32C-160S40LM	40.0	19.50	2	55.0	21.5	80	3.0	2.20	10800	10	N331.1A-11
		20.50	23.5	160	51.5	14	40	1	5	N331.32C-160S40QM	40.0	22.50	2	55.0	24.5	80	3.0	2.55	9000
23.50	26.5	160	51.5	14	40	1	5	N331.32C-160S40RM	40.0	25.50	2	55.0	27.5	80	3.0	2.78	9000	10	N331.1A-14

Reserve onderdelen				
CW	DC	Wisselplaat-schroef	Wigset	Schroef
6.0	80-160	5513 020-19	5431 105-07	5516 014-06
8.0	80-160	5513 020-34	5431 105-06	5516 014-05
10.0	80-160	5513 020-24	5431 105-01	269-832
12.0	80-160	5513 020-24	5431 105-02	269-832
15.0	100-160	5513 020-29	5431 105-04	5516 010-02
17.5	125-160	5513 020-29	5431 105-04	5516 010-02
20.5	160	5513 020-29	5431 105-05	5516 010-02
23.5	160	5513 020-29	5431 105-05	5516 010-02

Ga voor de complete lijst van reserveonderdelen naar www.sandvik.coromant.com

Onderdelen		
CZC _{MS}	Koelmiddelschroefset	Afstandsringset
27	5512 076-101	5549 091-032
32	5512 076-102	5549 091-042
40	5512 076-103	5549 091-052



CoroMill 331 instelbare schijffrees voor volprofiel- en vlakfreesen

Borst met spiebaan

KAPR 90°

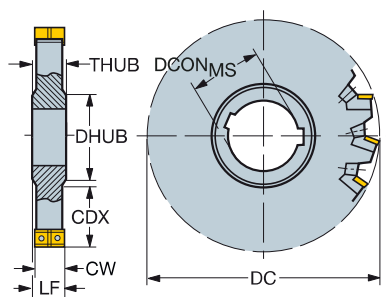
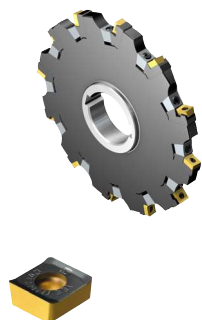

N331.1A

								Afmetingen, mm											
CW	CWX	DC	CDX		CZC _{MS}		Bestelnummer	DCON _{MS}	LF	DRVCT	DHUB	THUB			RPMX	CJCT	MIID		
6,00	8,0	200	64,5	04	50	8	N331.32-200S50CM06.00	50,0	10,00	2	69,0	14,0	0,8	1,34	11700	16	N331.1A-04		
8,00	10,0	200	64,5	05	50	8	N331.32-200S50DM08.00	50,0	12,00	2	69,0	16,0	1,2	1,67	9100	16	N331.1A-05		
10,00	12,0	200	64,5	08	50	8	N331.32-200S50EM10.00	50,0	13,00	2	69,0	16,0	1,2	1,98	11000	16	N331.1A-08		
12,00	15,0	200	64,5	08	50	8	N331.32-200S50FM12.00	50,0	14,00	2	69,0	16,0	1,2	2,38	11000	16	N331.1A-08		
15,00	17,5	200	64,5	11	50	6	N331.32-200S50KM15.00	50,0	16,75	2	69,0	18,5	3,0	2,88	9600	12	N331.1A-11		
		250	89,5	11	50	8	N331.32-250S50KM15.00	50,0	16,75	2	69,0	18,5	3,0	7,74	8500	16	N331.1A-11		
		315	114,5	11	60	10	N331.32-315S60KM15.00	60,0	16,75	2	84,0	18,5	3,0	13,20	7600	20	N331.1A-11		
17,50	20,5	200	64,5	11	50	6	N331.32-200S50LM17.50	50,0	19,50	2	69,0	21,5	3,0	3,29	9600	12	N331.1A-11		
		250	89,5	11	50	8	N331.32-250S50LM17.50	50,0	19,50	2	69,0	21,5	3,0	8,42	8500	16	N331.1A-11		
		315	114,5	11	60	10	N331.32-315S60LM17.50	60,0	19,50	2	84,0	21,5	3,0	12,94	7600	20	N331.1A-11		
20,50	23,5	200	64,5	14	50	6	N331.32-200S50QM20.50	50,0	22,50	2	69,0	24,5	3,0	3,86	8000	12	N331.1A-14		
		250	89,5	14	50	8	N331.32-250S50QM20.50	50,0	22,50	2	69,0	24,5	3,0	7,10	7100	16	N331.1A-14		
		315	114,5	14	60	10	N331.32-315S60QM20.50	60,0	22,50	2	84,0	24,5	3,0	14,28	6300	20	N331.1A-14		
23,50	26,5	200	64,5	14	50	6	N331.32-200S50RM23.50	50,0	25,50	2	69,0	27,5	3,0	4,35	8000	12	N331.1A-14		
		250	89,5	14	50	8	N331.32-250S50RM23.50	50,0	25,50	2	69,0	27,5	3,0	10,16	7100	16	N331.1A-14		
		315	114,5	14	60	10	N331.32-315S60RM23.50	60,0	25,50	2	84,0	27,5	3,0	19,26	6300	20	N331.1A-14		

Reserve onderdelen				
CW	DC	Wisselplaat-schroef	Wigset	Schroef
6,00	200,00	5513 020-19	5431 105-07	5516 014-06
8,00	200,00	5513 020-34	5431 105-06	5516 014-04
10,00	200,00	5513 020-24	5431 105-01	5516 010-02
12,00	200,00	5513 020-24	5431 105-02	5516 010-02
15,00-17,50	200,00-315,00	5513 020-29	5431 105-04	339-831
20,50-23,50	200,00-315,00	5513 020-29	5431 105-05	339-831

Ga voor de complete lijst van reserveonderdelen naar www.sandvik.coromant.com



I130



L2



N23





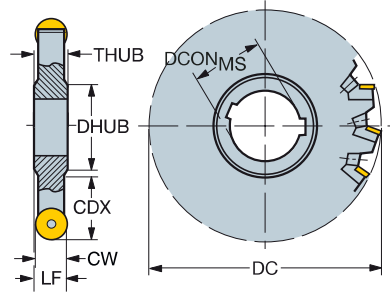

N6

CoroMill 331 instelbare schijffrees voor volprofiel- en vlakfrezes

Borst met spiebaan



RCKT
RCHT

						Afmetingen, mm											
CW	DC	CDX			Bestelnummer	DCON _{MS}	LF	DRVCT	DHUB	THUB			RPMX	RE	CICT	MID	
10,00	82	20,5	10	27	6	N331.32-082S27EMQ	27,0	13,00	1	39,0	16,0	3,0	0,56	18100	5,0	6	RCKT 10 T3 M0
	102	26,5	10	32	8	N331.32-102S32EMQ	32,0	13,00	1	47,0	16,0	3,0	0,50	15900	5,0	8	RCKT 10 T3 M0
	127	35,0	10	40	10	N331.32-127S40EMQ	40,0	13,00	2	55,0	16,0	3,0	1,03	14100	5,0	10	RCKT 10 T3 M0
	162	52,5	10	40	12	N331.32-162S40EMQ	40,0	13,00	2	55,0	16,0	3,0	1,51	12400	5,0	12	RCKT 10 T3 M0
	202	65,5	10	50	16	N331.32-202S50EMQ	50,0	13,00	2	69,0	16,0	3,0	2,03	11000	5,0	16	RCKT 10 T3 M0
12,00	82	20,5	12	27	6	N331.32-082S27FMQ	27,0	14,00	1	39,0	16,0	3,0	0,62	18100	6,0	6	RCKT 12 04 M0
	102	26,5	12	32	8	N331.32-102S32FMQ	32,0	14,00	1	47,0	16,0	3,0	0,89	15900	6,0	8	RCKT 12 04 M0
	127	35,0	12	40	10	N331.32-127S40FMQ	40,0	14,00	2	55,0	16,0	3,0	1,15	14100	6,0	10	RCKT 12 04 M0
	162	52,5	12	40	12	N331.32-162S40FMQ	40,0	14,00	2	55,0	16,0	3,0	1,73	12400	6,0	12	RCKT 12 04 M0
	202	65,5	12	50	16	N331.32-202S50FMQ	50,0	14,00	2	69,0	16,0	3,0	3,21	11000	6,0	16	RCKT 12 04 M0
16,00	102	26,5	16	32	6	N331.32-102S32KMQ	32,0	17,25	1	47,0	18,5	5,0	0,96	14000	8,0	6	RCKT 16 06 M0
	127	35,0	16	40	8	N331.32-127S40KMQ	40,0	17,25	1	55,0	18,5	5,0	1,27	12400	8,0	8	RCKT 16 06 M0
	162	52,5	16	40	10	N331.32-162S40KMQ	40,0	17,25	2	55,0	18,5	5,0	1,97	10800	8,0	10	RCKT 16 06 M0
	202	65,5	16	50	12	N331.32-202S50KMQ	50,0	17,25	2	69,0	18,5	5,0	3,20	9600	8,0	12	RCKT 16 06 M0

Reserve onderdelen				
CW	DC	Wisselplaat-schroef	Wigset	Schroef
10,00	82,00	5513 020-09	5431 105-01	269-832
10,00	102,00-202,00	5513 020-09	5431 105-01	339-831
12,00	82,00	5513 020-09	5431 105-02	269-832
12,00	102,00-202,00	5513 020-09	5431 105-02	339-831
16,00	102,00	5513 020-07	5431 105-04	5516 010-02
16,00	127,00-202,00	5513 020-07	5431 105-04	339-831

Ga voor de complete lijst van reserveonderdelen naar www.sandvik.coromant.com



1103



L2



N23







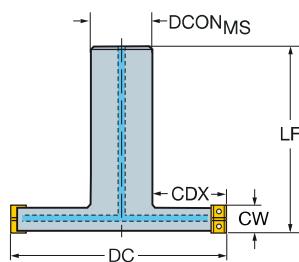
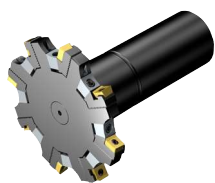

N6

CoroMill 331 instelbare schijffrees voor volprofiel- en vlakfreesen

Cilindrische schacht - interne koelmiddeltoevoer

KAPR 90°



											Afmetingen, mm						
CW	CWX	DC	CDX		CZC _{MS}	CNSC		Bestelnummer	DCON _{MS}	LF				RPMX	CICT	MIID	
6,00	8,0	80	23,0	04	32	1	3	R331.32C-080A32CM	32,0	115,00	80	0,8	0,90	19300	6	N331.1A-04	
		100	28,0	04	40	1	4	R331.32C-100A40CM	40,0	125,00	80	0,8	1,50	17100	8	N331.1A-04	
8,00	10,0	80	23,0	05	32	1	3	R331.32C-080A32DM	32,0	115,00	80	1,2	1,02	15000	6	N331.1A-05	
		100	28,0	05	40	1	4	R331.32C-100A40DM	40,0	125,00	80	1,2	1,65	13200	8	N331.1A-05	
10,00	12,0	80	23,0	08	32	1	3	R331.32C-080A32EM	32,0	115,00	80	1,2	1,04	18100	6	N331.1A-08	
		100	28,0	08	40	1	4	R331.32C-100A40EM	40,0	125,00	80	1,2	1,72	15900	8	N331.1A-08	

Reserve onderdelen				
CW	DC	Wisselplaat-schroef	Wigset	Schroef
6,0	80-100	5513 020-19	5431 105-07	5516 014-06
8,0	80-100	5513 020-34	5431 105-06	5516 014-05
10,0	80-100	5513 020-24	5431 105-01	269-832

Ga voor de complete lijst van reserveonderdelen naar www.sandvik.coromant.com



I130



L2



N23



N6

CoroMill 331 schijffrees voor volprofiel- en vlakfrezes

Baar met spiebaan - interne koelmiddeltoevoer

KAPR 90°

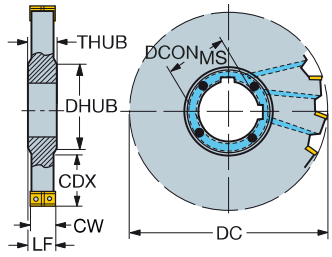

							Afmetingen, mm											
CW	DC	CDX		CZC _{MS}	CNSC		Bestelnummer	DCON _{MS}	LF	DRVCT	DHUB	THUB				RPMX	CICT	MIID
6.00	100	25.5	04	32	4	5	N331.35C-100S32CM060	32.0	7.00	2	47.0	8.0	80	0.8	0.21	17000	10	N331.1A-04
8.00	100	25.5	05	32	4	5	N331.35C-100S32DM080	32.0	9.00	2	47.0	10.0	80	1.2	0.28	13000	10	N331.1A-05
	125	34.0	05	40	4	6	N331.35C-125S40DM080	40.0	9.00	2	55.0	10.0	80	1.2	0.47	15000	12	N331.1A-05
10.00	125	34.0	08	40	4	6	N331.35C-125S40EM100	40.0	11.00	2	55.0	12.0	80	1.2	0.61	11500	12	N331.1A-08

		Reserve onderdelen
CW	DC	Wisselplaat-schroef
6.0	100.00	5513 020-19
8.0	100.00-125.00	5513 020-34
10.0	125.00	5513 020-24

Ga voor de complete lijst van reserveonderdelen naar www.sandvik.coromant.com



CoroMill 331 schijffrees voor volprofiel- en vlakfrezen

Cilindrische schacht - interne koelmiddeltoevoer

KAPR 90°

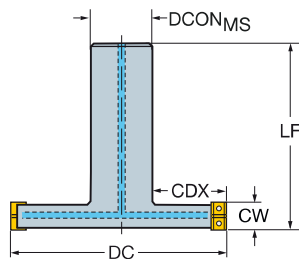

								Afmetingen, mm							
CW	DC	CDX		CZC _{MS}	CNSC		Bestelnummer	DCON _{MS}	LF				RPMX	CICT	MIID
6,00	40	11,0	04	16	1	2	R331.35C-040A16CM060	16,0	120,00	80	0,8	0,19	29500	4	N331,1A-04
	50	14,0	04	20	1	3	R331.35C-050A20CM060	20,0	130,00	80	0,8	0,33	25000	6	N331,1A-04
	63	18,0	04	25	1	3	R331.35C-063A25CM060	25,0	140,00	80	0,8	0,58	22000	6	N331,1A-04
	80	23,0	04	32	1	4	R331.35C-080A32CM060	32,0	150,00	80	0,8	1,03	19000	8	N331,1A-04
8,00	40	11,0	05	16	1	2	R331.35C-040A16DM080	16,0	120,00	80	1,2	0,19	22300	4	N331,1A-05
	50	14,0	05	20	1	3	R331.35C-050A20DM080	20,0	130,00	80	1,2	0,34	19500	6	N331,1A-05
	63	18,0	05	25	1	3	R331.35C-063A25DM080	25,0	140,00	80	1,2	0,60	17000	6	N331,1A-05
	80	23,0	05	32	1	4	R331.35C-080A32DM080	32,0	150,00	80	1,2	1,06	15000	8	N331,1A-05
10,00	40	11,0	08	16	1	2	R331.35C-040A16EM100	16,0	120,00	80	1,2	0,20	27000	4	N331,1A-08
	50	14,0	08	20	1	3	R331.35C-050A20EM100	20,0	130,00	80	1,2	0,42	23500	6	N331,1A-08
	63	18,0	08	25	1	3	R331.35C-063A25EM100	25,0	140,00	80	1,2	0,62	21000	6	N331,1A-08
	80	23,0	08	32	1	4	R331.35C-080A32EM100	32,0	150,00	80	1,2	1,11	18000	8	N331,1A-08

		Reserve onderdelen
CW	DC	Wisselplaat-schroef
6,0	40,00-80,00	5513 020-19
8,0	40,00-80,00	5513 020-34
10,0	40,00-80,00	5513 020-24

Ga voor de complete lijst van reserveonderdelen naar www.sandvik.coromant.com



I130



L2



N23



N6

CoroMill 331 instelbare schijffrees voor tweezijdig- en vlakfreen

Doorn

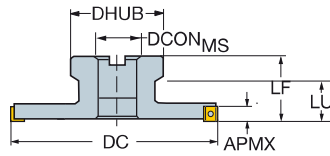
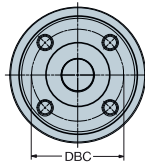
STDNO
KAPRISO6462
90°

N331.1A

						Afmetingen, mm											
DC	CZC _{MS}	APMX	Bestelnummer	DCON _{MS}	ISO	DBC	LF	LU	DHUB	NM	KG	RPMX	CICT	MIID			
80	08	27	7.6	6	R331.52-080Q27FMR	27.0	A	63.00	40	54.0	1.2	1.12	18100	6	N331.1A-08		
80	08	27	7.6	6	R331.52-080Q27EMR	27.0	A	63.00	40	54.0	1.2	0.80	18100	6	N331.1A-08		
100	08	27	7.6	8	R331.52-100Q27FMR	27.0	A	63.00		54.0	1.2	1.30	15900	8	N331.1A-08		
125	08	32	7.6	10	R331.52-125Q32FMR	32.0	B	63.00		64.0	1.2	1.95	14100	10	N331.1A-08		
125	08	32	7.6	10	R331.52-125Q32EMR	32.0	B	63.00		64.0	1.2	1.86	14100	10	N331.1A-08		
160	08	40	7.6	12	R331.52-160Q40EMR	40.0	B	63.00		76.0	1.2	2.69	12400	12	N331.1A-08		
100	11	27	10.6	6	R331.52-100Q27KMR	27.0	A	63.00	40	54.0	3.0	1.77	14000	6	N331.1A-11		
125	11	32	10.6	8	R331.52-125Q32KMR	32.0	B	63.00		64.0	3.0	2.30	12000	8	N331.1A-11		
160	11	40	10.6	10	R331.52-160Q40KMR	40.0	B	63.00		76.0	3.0	3.30	10800	10	N331.1A-11		
200	11	40S	10.6	12	R331.52-200Q40MMR	40.0	C	66.7	63.00	96.0	3.0	11.50	9600	12	N331.1A-11		

Reserve onderdelen			
Bestelnummer	Wisselplaat-schroef	Wigset	Schroef
R331.52-080Q27EMR	5513 020-24	5431 105-01	269-832
R331.52-080Q27FMR	5513 020-24	5431 105-02	269-832
R331.52-100Q27FMR	5513 020-24	5431 105-02	5516 010-02
R331.52-125Q32EMR	5513 020-24	5431 105-01	339-831
R331.52-125Q32FMR	5513 020-24	5431 105-02	339-831
R331.52-160Q40EMR	5513 020-24	5431 105-01	339-831
R331.52-160Q40FMR	5513 020-24	5431 105-02	339-831
R331.52-100Q27KMR	5513 020-29	5431 105-04	339-831
R331.52-125Q32KMR	5513 020-29	5431 105-04	339-831
R331.52-160Q40KMR	5513 020-29	5431 105-04	339-831
R331.52-200Q40MMR	5513 020-29	5431 105-03	339-831
R331.52-250Q60MMR	5513 020-29	5431 105-03	339-831
R331.52-315Q60NMR	5513 020-29	5431 105-04	339-831

Ga voor de complete lijst van reserveonderdelen naar www.sandvik.coromant.com

I130



L2



M1



N23



N6

CoroMill 331 instelbare schijffrees voor tweezijdig- en vlakfrezes

Cilindrische schacht

KAPR 90°

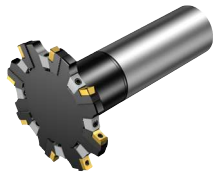

N331.1A

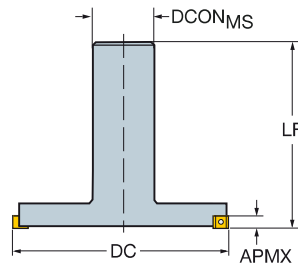

					Afmetingen, mm							
DC	CZC _{MS}	APMX	Bestelnummer		DCON _{MS}	LF	NM	KG	RPMX	CICT	MIID	
100	08	42	7.6	8	R331.52-100A42EMR	42.0	152.00	1.2	1.90	15900	8	N331.1A-08

Reserve onderdelen		
Wisselplaat-schroef	Wigset	Schroef
5513 020-24	5431 105-01	339-831

Ga voor de complete lijst van reserveonderdelen naar www.sandvik.coromant.com

CoroMill 331 Instelbare tweezijdige schijffrees

Cilindrische schacht

KAPR 90°



N331.1A

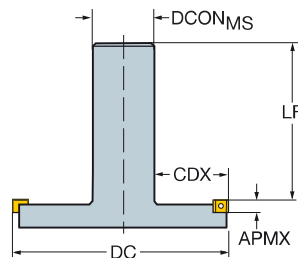

					Afmetingen, mm								
DC	CDX	CZC _{MS}	APMX	Bestelnummer		DCON _{MS}	LF	NM	KG	RPMX	CICT	MIID	
80	19.5	08	32	7.6	6	R331.52-080A32EML	32.0	122.00	1.2	1.19	18100	6	N331.1A-08
100	25.5	08	42	7.6	8	R331.52-100A42EML	42.0	142.00	1.2	1.90	15900	8	N331.1A-08

Reserve onderdelen		
Wisselplaat-schroef	Wigset	Schroef
5513 020-24	5431 105-01	339-831

Ga voor de complete lijst van reserveonderdelen naar www.sandvik.coromant.com

I130



L2



M1



N23



N6



CoroMill 331 Instelbare tweezijdige schijffrees

Borst met spiebaan

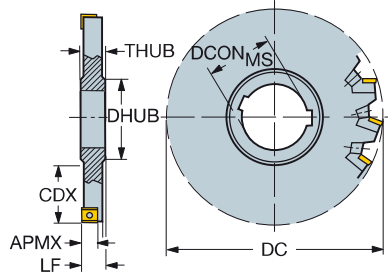
KAPR 90°



N331,1A

						Afmetingen, mm											
DC	CDX		CZC_{MS}	APMX		Bestelnummer	$DCON_{MS}$	LF	DRVCT	DHUB	THUB	NM	KG	RPMX	CICT	MIID	
80	19.5	08	27	7.6	6	R/L331.52-080S27EM	27.0	13.00	1	39.0	16.0	1.2	0.54	18100	6	N331.1A-08	
80	19.5	08	27	7.6	6	R/L331.52-080S27FM	27.0	14.00	1	39.0	16.0	1.2	0.56	18100	6	N331.1A-08	
100	25.5	08	32	7.6	8	R/L331.52-100S32EM	32.0	13.00	1	47.0	16.0	1.2	0.84	15900	8	N331.1A-08	
100	25.5	08	32	7.6	8	R/L331.52-100S32FM	32.0	14.00	1	47.0	16.0	1.2	0.60	15900	8	N331.1A-08	
125	34.0	08	40	7.6	10	R/L331.52-125S40EM	40.0	13.00	2	55.0	16.0	1.2	1.02	14100	10	N331.1A-08	
125	34.0	08	40	7.6	10	R/L331.52-125S40FM	40.0	14.00	2	55.0	16.0	1.2	1.13	14100	10	N331.1A-08	
160	51.5	08	40	7.6	12	R/L331.52-160S40EM	40.0	13.00	2	55.0	16.0	1.2	1.50	12400	12	N331.1A-08	
160	51.5	08	40	7.6	12	R/L331.52-160S40FM	40.0	14.00	2	55.0	16.0	1.2	1.73	12400	12	N331.1A-08	
100	25.5	11	32	10.6	6	L331.52-100S32KM	32.0	16.75	1	47.0	18.5	3.0	0.94	14000	6	N331.1A-11	
125	34.0	11	40	10.6	8	R/L331.52-125S40KM	40.0	16.75	1	55.0	18.5	3.0	1.30	12000	8	N331.1A-11	
160	51.5	11	40	10.6	10	R/L331.52-160S40KM	40.0	16.75	2	55.0	18.5	3.0	2.00	10000	10	N331.1A-11	
200	64.5	11	50	10.6	12	R/L331.52-200S50MM	50.0	29.20	2	69.0	31.2	3.0	9.90	9600	12	N331.1A-11	
250	89.5	11	50	10.6	16	L331.52-250S50MM	50.0	29.20	2	69.0	31.2	3.0	12.96	8500	16	N331.1A-11	
315	114.5	11	60	10.6	20	R/L331.52-315S60NM	60.0	32.80	2	84.0	34.8	3.0	17.30	7600	20	N331.1A-11	

Reserve onderdelen			
Bestelnummer	Wisselplaat-schroef	Wigset	Schroef
R/L331.52-125S40EM	5513 020-24	5431 105-01	339-831
R/L331.52-125S40FM	5513 020-24	5431 105-02	339-831
R/L331.52-160S40EM	5513 020-24	5431 105-01	339-831
R/L331.52-160S40FM	5513 020-24	5431 105-02	339-831
R/L331.52-080S27EM	5513 020-24	5431 105-01	269-832
R/L331.52-080S27FM	5513 020-24	5431 105-02	269-832
R/L331.52-100S32EM	5513 020-24	5431 105-01	339-831
R/L331.52-100S32FM	5513 020-24	5431 105-02	339-831
R/L331.52-160S40KM	5513 020-29	5431 105-04	339-831
R/L331.52-200S50MM	5513 020-29	5431 105-03	339-831
R/L331.52-250S50MM	5513 020-29	5431 105-03	339-831
R/L331.52-315S60NM	5513 020-29	5431 105-04	339-831
R/L331.52-100S32KM	5513 020-29	5431 105-04	5516 010-02
R/L331.52-125S40KM	5513 020-29	5431 105-04	339-831

Ga voor de complete lijst van reserveonderdelen naar www.sandvik.coromant.com



I130



L2



N23



N6

CoroMill 331 Instelbare tweezijdige schijffrees

Doorn

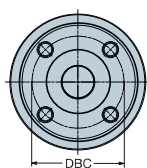
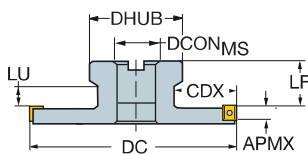
STDNO
KAPRISO6462
90°

N331.1A

						Afmetingen, mm												
DC	CDX	CZC _{MS}	APMX	Bestelnummer		DCON _{MS}	ISO	DBC	LF	LU	DHUB	NM	KG	RPMX	CICT	MIID		
80	20,0	08	27	7,6	6	R331.52-080Q27EML	27,0	A	53,00	30	54,0	1,2	0,80	18100	6	N331.1A-08		
80	20,0	08	27	7,6	6	R331.52-080Q27FML	27,0	A	51,00	28	54,0	1,2	0,98	18100	6	N331.1A-08		
100	22,0	08	27	7,6	8	R331.52-100Q27EML	27,0	A	53,00		54,0	1,2	1,20	15900	8	N331.1A-08		
100	22,0	08	27	7,6	8	R331.52-100Q27FML	27,0	A	51,00		54,0	1,2	1,30	15900	8	N331.1A-08		
125	29,5	08	32	7,6	10	R331.52-125Q32EML	32,0	B	51,00		64,0	1,2	1,95	14100	10	N331.1A-08		
125	29,5	08	32	7,6	10	R331.52-125Q32FML	32,0	B	53,00		64,0	1,2	1,81	14100	10	N331.1A-08		
160	41,0	08	40	7,6	12	R331.52-160Q40EML	40,0	B	51,00		76,0	1,2	2,90	12400	12	N331.1A-08		
160	41,0	08	40	7,6	12	R331.52-160Q40FML	40,0	B	53,00		76,0	1,2	2,60	12400	12	N331.1A-08		
100	25,7	11	27	10,6	6	R331.52-100Q27KML	27,0	A	48,00	25	54,0	3,0	1,77	14000	6	N331.1A-11		
125	29,5	11	32	10,6	8	R331.52-125Q32KML	32,0	B	48,00		64,0	3,0	2,09	12000	8	N331.1A-11		
160	41,0	11	40	10,6	10	R331.52-160Q40KML	40,0	B	48,00		76,0	3,0	3,02	10800	10	N331.1A-11		
200	51,0	11	40S	10,6	12	R331.52-200Q40MML	40,0	C	66,7	35,80	96,0	3,0	11,12	9600	12	N331.1A-11		

Reserve onderdelen			
Bestelnummer	Wisselplaat-schroef	Wigset	Schroef
R331.52-080Q27EML	5513 020-24	5431 105-01	269-832
R331.52-080Q27FML	5513 020-24	5431 105-02	269-832
R331.52-100Q27EML	5513 020-24	5431 105-01	5516 010-02
R331.52-100Q27FML	5513 020-24	5431 105-02	5516 010-02
R331.52-125Q32EML	5513 020-24	5431 105-01	339-831
R331.52-125Q32FML	5513 020-24	5431 105-02	339-831
R331.52-160Q40EML	5513 020-24	5431 105-01	339-831
R331.52-160Q40FML	5513 020-24	5431 105-02	339-831
R331.52-100Q27KML	5513 020-29	5431 105-04	339-831
R331.52-125Q32KML	5513 020-29	5431 105-04	339-831
R331.52-160Q40KML	5513 020-29	5431 105-04	339-831
R331.52-200Q40MML	5513 020-29	5431 105-03	339-831
R331.52-250Q60MML	5513 020-29	5431 105-03	339-831
R331.52-315Q60NML	5513 020-29	5431 105-04	339-831

Ga voor de complete lijst van reserveonderdelen naar www.sandvik.coromant.com

I130



L2



M1



N23



N6

CoroMill® 331 wisselplaat voor schijffrees

KRINS 90°

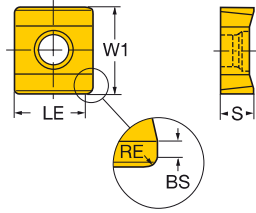
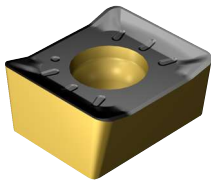

Licht	RE	Bestelnummer	P		M		K		N		S		H		Afmetingen, mm														
			1130	4340	530	1040	1130	2040	530	1020	3040	3220	3380	530	H10	H13A	1130	2040	H13A	S30T	1130	530	W1	LE	S	BS			
Licht	04	0.50	N331.1A-04 35 05E-KL	☆	☆	☆			☆	☆	☆	☆												9,5	4,6	3,50	0,4		
		0.50	N331.1A-04 35 05H-NL	☆	☆	☆			☆		☆	☆		☆											9,5	4,6	3,50	0,2	
		0.50	N331.1A-04 35 05H-PL	☆	☆	☆																			9,5	4,6	3,50	0,4	
		0.50	N331.1A-04 35 05H-WL	☆	☆	☆					☆		☆	☆	☆	☆	☆								9,5	4,6	3,50	0,4	
		0.50	N331.1A-043505E-L30				☆	☆								☆	☆								9,5	4,6	3,49	0,4	
		0.50	N331.1A-043505E-L50	☆			☆	☆								☆	☆								9,5	4,6	3,49	0,4	
	Licht	05	0.80	N331.1A-05 45 08E-KL						☆	☆	☆													9,5	5,7	4,45	1,2	
			0.80	N331.1A-05 45 08H-NL	☆			☆				☆	☆													9,5	5,7	4,45	0,8
			0.80	N331.1A-05 45 08H-PL	☆	☆	☆																			9,5	5,7	4,45	1,2
			0.80	N331.1A-05 45 08H-WL	☆			☆				☆	☆	☆	☆	☆	☆									9,5	5,7	4,45	1,2
			0.80	N331.1A-054508E-L30				☆	☆								☆	☆								9,5	5,7	4,49	1,2
			0.80	N331.1A-054508E-L50	☆			☆	☆								☆	☆								9,5	5,7	4,49	1,2
Licht		08	0.80	N331.1A-08 45 08E-KL						☆	☆	☆													9,5	7,7	4,45	1,2	
			0.80	N331.1A-08 45 08H-NL	☆			☆				☆	☆													9,5	7,7	4,45	0,9
		0.80	N331.1A-08 45 08H-PL	☆	☆	☆																			9,5	7,7	4,45	1,2	
		0.80	N331.1A-08 45 08H-WL	☆		☆	☆	☆			☆	☆	☆	☆	☆	☆									9,5	7,7	4,45	1,2	
		2.00	N331.1A-08 45 20E-KL						☆																9,5	6,5	4,50	1,2	
		2.00	N331.1A-08 45 20H-PL	☆			☆																		9,5	6,5	4,50	1,2	
		0.80	N331.1A-084508E-L30				☆	☆								☆	☆								9,5	7,7	4,49	1,2	
		0.80	N331.1A-084508E-L50	☆			☆	☆								☆	☆								9,5	7,7	4,49	1,2	
	Licht	11	0.80	N331.1A-11 50 08E-KL						☆	☆	☆													11,5	10,7	4,95	1,2	
			0.80	N331.1A-11 50 08H-NL	☆			☆				☆	☆													11,5	10,7	4,95	1,3
			0.80	N331.1A-11 50 08H-PL	☆	☆	☆																			11,5	10,7	4,95	1,2
			0.80	N331.1A-11 50 08H-WL	☆			☆				☆	☆	☆	☆	☆	☆									11,5	10,7	4,95	1,2
		2.00	N331.1A-11 50 20E-KL						☆																11,5	9,5	5,00	1,2	
		2.00	N331.1A-11 50 20H-PL	☆			☆																		11,5	9,5	5,00	1,2	
		0.80	N331.1A-115008E-L30				☆	☆								☆	☆								11,5	10,7	4,99	1,2	
		0.80	N331.1A-115008E-L50	☆			☆	☆								☆	☆								11,5	10,7	4,99	1,2	
Licht		14	0.80	N331.1A-14 50 08E-KL						☆	☆	☆													11,5	13,7	4,95	1,2	
			0.80	N331.1A-14 50 08H-NL	☆			☆				☆	☆													11,5	13,7	4,95	1,1
			0.80	N331.1A-14 50 08H-PL	☆	☆	☆																			11,5	13,7	4,95	1,2
			0.80	N331.1A-14 50 08H-WL	☆			☆				☆	☆	☆	☆	☆	☆									11,5	13,7	4,95	1,2
		0.80	N331.1A-145008E-L30				☆	☆								☆	☆								11,5	13,7	4,98	1,2	
		0.80	N331.1A-145008E-L50	☆			☆	☆								☆	☆								11,5	13,7	4,98	1,2	
	Middelmatig	04	0.50	N331.1A-04 35 05M-KM						☆	☆	☆													9,5	4,6	3,50	0,4	
			0.50	N331.1A-04 35 05M-PM	☆	☆	☆																			9,5	4,6	3,50	0,4
		0.50	N331.1A-043505E-M30	☆	☆				☆	☆															9,5	4,6	3,50	0,4	
Middelmatig		05	0.80	N331.1A-05 45 08E-KM						☆	☆	☆													9,5	5,7	4,45	1,2	
			0.80	N331.1A-05 45 08H-PM	☆			☆																		9,5	5,7	4,45	1,2
			0.80	N331.1A-05 45 08M-KM				☆	☆	☆	☆															9,5	5,7	4,45	1,2
			0.80	N331.1A-05 45 08M-PM	☆	☆																				9,5	5,7	4,45	1,2
			0.80	N331.1A-054508E-M30	☆	☆				☆	☆															9,5	5,7	4,50	1,2
		Middelmatig	08	0.80	N331.1A-08 45 08E-KM						☆	☆	☆													9,5	7,7	4,45	1,2
			0.80	N331.1A-08 45 08H-PM	☆			☆																		9,5	7,7	4,45	1,2
			0.80	N331.1A-08 45 08H-WM			☆		☆			☆	☆													9,5	7,7	4,45	1,2
			0.80	N331.1A-08 45 08M-KM				☆	☆	☆	☆															9,5	7,7	4,45	1,2
	0.80		N331.1A-08 45 08M-PM	☆	☆																				9,5	7,7	4,45	1,2	
	2.00		N331.1A-08 45 20E-KM						☆	☆															9,5	6,5	4,45	1,2	
	2.00		N331.1A-08 45 20H-PM	☆	☆		☆				☆														9,5	6,5	4,45	1,2	
	0.80		N331.1A-084508E-M30	☆	☆				☆	☆															9,5	7,7	4,50	1,2	



I116

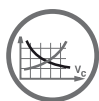

I154



I175



N23



N6



N10

CoroMill® 331 wisselplaat voor schijffrees

KRINS 90°

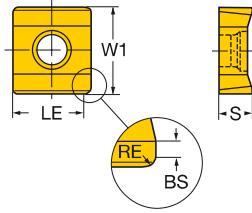
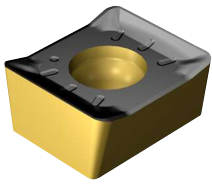

	RE	Bestelnummer	P		M		K		N		S		H		Afmetingen, mm																
			1130	4330	4340	530	1040	1130	2040	530	1020	3040	3220	3360	1130	530	H10	H13A	1130	2040	H13A	LS30T	1130	530	W1	LE	S	BS			
Medium	11	0,80	N331.1A-11 50 08E-KM																							11,5	10,7	4,95	1,2		
		0,80	N331.1A-11 50 08H-PM	☆																							11,5	10,7	4,95	1,2	
	0,80	N331.1A-11 50 08H-WM			☆																						11,5	10,7	4,95	1,2	
	0,80	N331.1A-11 50 08M-KM									☆	☆	☆	☆													11,5	10,7	4,95	1,2	
	0,80	N331.1A-11 50 08M-PM		☆	☆																						11,5	10,7	4,95	1,2	
	2,00	N331.1A-11 50 20E-KM										★	★														11,5	9,5	4,95	1,2	
	2,00	N331.1A-11 50 20H-PM	★	★		☆								☆													11,5	9,5	4,95	1,2	
	0,80	N331.1A-115008E-M30	★	★																							11,5	10,7	5,00	1,2	
	14	0,80	N331.1A-14 50 08E-KM																									11,5	13,7	4,95	1,2
		0,80	N331.1A-14 50 08H-PM																									11,5	13,7	4,95	1,2
		0,80	N331.1A-14 50 08H-WM																									11,5	13,7	4,95	1,2
		0,80	N331.1A-14 50 08M-KM																									11,5	13,7	4,95	1,2
		0,80	N331.1A-14 50 08M-PM																									11,5	13,7	4,95	1,2
		0,80	N331.1A-145008E-M30	★	★																							11,5	13,7	5,00	1,2



I116

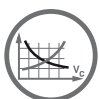

I154



I175



N23



N6



N10

CoroMill® 331 wisselplaat voor schijffrees

Freeslichamen voor radii-wisselplaten leverbaar als Tailor Made.

KRINS 90°

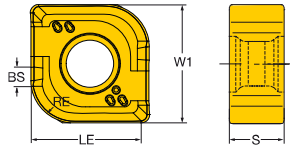
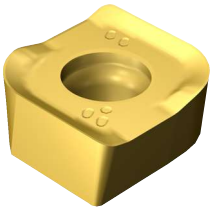

		SSC	RE	Bestelnummer	P		M			K	N	S		H	Afmetingen, mm			
					1130	4330	1040	1130	2040	S30T	1020	3040	1130	1130	2040	S30T	1130	W1
Licht	L50	11	3,05	R/L331.1A-115030E-L50		★		☆	☆				☆	★	11,5	10,7	5,00	1,3
			4,00	R/L331.1A-115040E-L50		★		☆	☆				☆	★	11,5	10,7	5,00	1,4
			4,83	R/L331.1A-115048E-L50		★		☆	☆				☆	★	11,5	10,7	5,00	1,5
			6,35	R/L331.1A-115063E-L50		★		☆	☆				☆	★	11,5	10,7	5,00	1,6
Middelmatig	M30	11	1,52	R/L331.1A-115015E-M30	★	☆		☆		★	☆	☆	☆	☆	11,5	10,7	5,00	1,2
			2,29	R/L331.1A-115023E-M30	★	☆		☆		★	☆	☆	☆	☆	11,5	10,7	5,00	1,2
			3,05	R/L331.1A-115030E-M30	★	☆		☆		★	☆	☆	☆	☆	11,5	10,7	5,00	1,3
	WM	08	4,00	R/L331.1A-08 45 40H-WM	★	☆		☆		★	☆	☆	☆	☆	9,5	7,7	4,45	1,4
		11	4,00	R/L331.1A-11 50 40H-WM	★	☆		☆		★	☆	☆	☆	☆	11,5	10,7	4,95	1,4
		14	4,00	R/L331.1A-14 50 40H-WM	★	☆		☆		★	☆	☆	☆	☆	11,5	13,7	4,95	1,4



I116

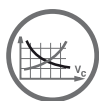

I154



I175



N23



N6



N10

CoroMill® 331 wisselplaat voor schijffrees

Freeslichamen voor radii-wisselplaten leverbaar als Tailor Made.

KRINS 90°

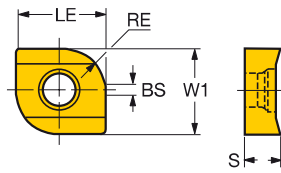
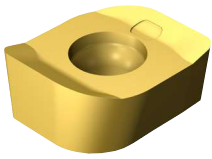

Licht	WL	RE	Bestelnummer	Afmetingen, mm															
				P		M		K		N		S		H					
				1130	4940	1040	1130	1025	4940	1130	H10F	1040	1130	S30T	H10F	1130			
	04	1.52	L331.1A-04 35 15H-WL	★	★	★	☆	☆	☆	☆	★	☆	★	☆	★	9.5	4.6	3.50	0.4
		2.29	L331.1A-04 35 23H-WL	★	★	★	☆	☆	☆	☆	★	☆	★	☆	★	9.5	4.6	3.50	0.4
		1.52	R331.1A-04 35 15H-WL	★	★	★	☆	☆	☆	☆	★	☆	★	☆	★	9.5	4.6	3.50	0.4
		2.29	R331.1A-04 35 23H-WL	★	★	★	☆	☆	☆	☆	★	☆	★	☆	★	9.5	4.6	3.50	0.4
	05	1.52	L331.1A-05 45 15H-WL	★	★	★	☆	☆	☆	☆	★	☆	★	☆	★	9.5	5.7	4.45	1.2
		2.29	L331.1A-05 45 23H-WL	★	★	★	☆	☆	☆	★	★	☆	★	☆	★	9.5	5.7	4.45	1.2
		3.05	L331.1A-05 45 30H-WL	★	★	★	☆	☆	☆	☆	★	☆	★	☆	★	9.5	5.7	4.45	1.3
		1.52	R331.1A-05 45 15H-WL	★	★	★	☆	☆	☆	☆	★	☆	★	☆	★	9.5	5.7	4.45	1.2
		2.29	R331.1A-05 45 23H-WL	★	★	★	☆	☆	☆	★	★	☆	★	☆	★	9.5	5.7	4.45	1.2
		3.05	R331.1A-05 45 30H-WL	★	★	★	☆	☆	☆	☆	★	☆	★	☆	★	9.5	5.7	4.45	1.3
	08	1.52	L331.1A-08 45 15H-WL	★	★	★	☆	☆	☆	☆	★	☆	★	☆	★	9.5	7.7	4.45	1.2
		2.29	L331.1A-08 45 23H-WL	★	★	★	☆	☆	☆	★	★	☆	★	☆	★	9.5	7.7	4.45	1.2
		3.05	L331.1A-08 45 30H-WL	★	★	★	☆	☆	☆	★	★	☆	★	☆	★	9.5	7.7	4.45	1.3
		1.52	R331.1A-08 45 15H-WL	★	★	★	☆	☆	☆	☆	★	☆	★	☆	★	9.5	7.7	4.45	1.2
		2.29	R331.1A-08 45 23H-WL	★	★	★	☆	☆	☆	★	★	☆	★	☆	★	9.5	7.7	4.45	1.2
		3.05	R331.1A-08 45 30H-WL	★	★	★	☆	☆	☆	☆	★	☆	★	☆	★	9.5	7.7	4.45	1.3
	11	1.52	L331.1A-11 50 15H-WL	★	★	★	☆	☆	☆	☆	★	☆	★	☆	★	11.5	10.7	4.95	1.2
		2.29	L331.1A-11 50 23H-WL	★	★	★	☆	☆	☆	★	★	☆	★	☆	★	11.5	10.7	4.95	1.2
		3.05	L331.1A-11 50 30H-WL	★	★	★	☆	☆	☆	☆	★	☆	★	☆	★	11.5	10.7	4.95	1.3
		4.83	L331.1A-11 50 48H-WL	★	★	★	☆	☆	☆	☆	★	☆	★	☆	★	11.5	10.7	4.95	1.5
		6.35	L331.1A-11 50 63H-WL	★	★	★	☆	☆	☆	☆	★	☆	★	☆	★	11.5	10.7	4.95	1.6
		1.52	R331.1A-11 50 15H-WL	★	★	★	☆	☆	☆	☆	★	☆	★	☆	★	11.5	10.7	4.95	1.2
		2.29	R331.1A-11 50 23H-WL	★	★	★	☆	☆	☆	★	★	☆	★	☆	★	11.5	10.7	4.95	1.2
		3.05	R331.1A-11 50 30H-WL	★	★	★	☆	☆	☆	☆	★	☆	★	☆	★	11.5	10.7	4.95	1.3
		4.83	R331.1A-11 50 48H-WL	★	★	★	☆	☆	☆	☆	★	☆	★	☆	★	11.5	10.7	4.95	1.5
		6.35	R331.1A-11 50 63H-WL	★	★	★	☆	☆	☆	☆	★	☆	★	☆	★	11.5	10.7	4.95	1.6
	14	1.52	L331.1A-14 50 15H-WL	★	★	★	☆	☆	☆	☆	★	☆	★	☆	★	11.5	13.7	4.95	1.2
		2.29	L331.1A-14 50 23H-WL	★	★	★	☆	☆	☆	☆	★	☆	★	☆	★	11.5	13.7	4.95	1.2
		3.05	L331.1A-14 50 30H-WL	★	★	★	☆	☆	☆	☆	★	☆	★	☆	★	11.5	13.7	4.95	1.3
		4.83	L331.1A-14 50 48H-WL	★	★	★	☆	☆	☆	☆	★	☆	★	☆	★	11.5	13.7	4.95	1.5
		6.35	L331.1A-14 50 63H-WL	★	★	★	☆	☆	☆	☆	★	☆	★	☆	★	11.5	13.7	4.95	1.6
		1.52	R331.1A-14 50 15H-WL	★	★	★	☆	☆	☆	☆	★	☆	★	☆	★	11.5	13.7	4.95	1.2
		2.29	R331.1A-14 50 23H-WL	★	★	★	☆	☆	☆	☆	★	☆	★	☆	★	11.5	13.7	4.95	1.2
		3.05	R331.1A-14 50 30H-WL	★	★	★	☆	☆	☆	☆	★	☆	★	☆	★	11.5	13.7	4.95	1.3
		4.83	R331.1A-14 50 48H-WL	★	★	★	☆	☆	☆	☆	★	☆	★	☆	★	11.5	13.7	4.95	1.5
		6.35	R331.1A-14 50 63H-WL	★	★	★	☆	☆	☆	☆	★	☆	★	☆	★	11.5	13.7	4.95	1.6

Beperkingen bij het gebruik van wisselplaten met grote hoekradius

"Vol" frezen

Wisselplaat afmeting	Berekende CW
04	$CW = RE + 4.6$
05	$CW = RE + 6$
08	$CW = RE + 8$
11	$CW = RE + 11$

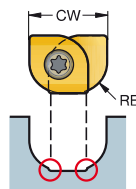

I116

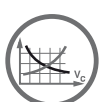

I154



I175



N23



N6



N10

CoroMill® 331 wisselplaat voor schijffrees

KRINS 88°

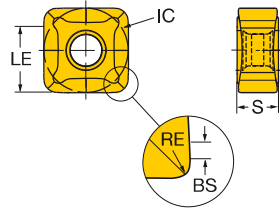
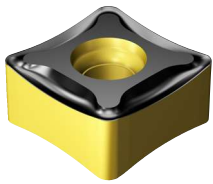

	RE	Bestelnummer	P		M	K	N	S	H	Afmetingen, mm						
			1130	4220	4330	4340	1130	1020	3040	3380	1130	1130	1130	IC	LE	S
Middelmatig PM	13	0,80	N331.1D-136508E-PM	☆		★	☆	☆	☆	☆	☆	☆	13,4	11,4	6,55	1,2
		0,80	N331.1D-136508M-PM	☆	☆	★		☆	☆	☆	☆	☆	13,4	11,4	6,55	1,2
		1,20	N331.1D-136512M-PM	☆	☆	☆	☆	☆	★		☆	☆	13,4	11,0	6,55	1,2
		2,00	N331.1D-136520E-PM	☆	☆	★	☆	☆	☆	☆	☆	☆	13,4	10,2	6,55	1,2
		2,00	N331.1D-136520M-PM	☆	☆	☆	☆	☆	★		☆	☆	13,4	10,2	6,55	1,2

Deze dubbelzijdige wisselplaten hebben optionele cassettes nodig. Zie hieronder voor meer informatie.

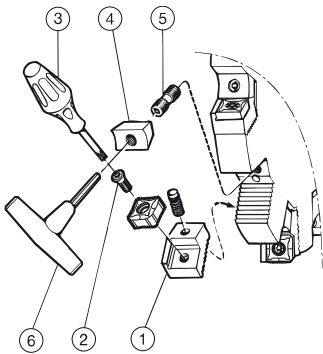

Houd er rekening mee dat de diameter van de frees met 3,2 mm toeneemt bij het gebruik van de cassettes voor dubbelzijdige wisselplaten.

Frees type	1	1	2	3	4	5	6	
	Cassette Rechts	Cassette Links	Schroef	Sleutel (Torx Plus)	Draaimoment-sleutel ¹⁾	Wigset	Schroef	Sleutel (mm)
QM (a _b 20,5-23,5 mm)	5321 260-01	5321 260-02	5513 020-25	5680 046-02 (15IP)	5680 100-06	5431 105-05	339-831	265.2-817 (3.0)
RM (a _b 23,5-26,5 mm)	5321 260-01	5321 260-02	5513 020-25	5680 046-02 (15IP)	5680 100-06	5431 105-05	339-831	265.2-817 (3.0)

1) Optioneel onderdeel, a.u.b. afzonderlijk bestellen



I116

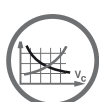

I154



I175



N23



N6



N10